

- 1 Individual sample  
2 Tour sample

## Description

The **Sampler PS4-S** designed to be installed on milk collecting trucks works according to the principle of a hose pump and enables you to take the samples directly from the hose pipe. The **PS4-S** can be equipped with two pump heads; it consists of the sampler in a stainless steel housing and a separate control unit in an aluminium housing.

### Special Features:

- Simultaneous taking of 2 independent and individual samples possible.
- Quasi-continuous operation because step motors are used.
- Improved lifetime of the hose due to a redesigned pump head and speed limiter.
- Good representability due to a very low sampling volume of the individual samples and frequent taking of individual samples.
- Low carry-over because of small moistening areas in the system. Suitable for bacteriological sampling.
- Easy installation.
- Good cleaning capability.
- Few maintenance required.
- Bottle holders for different sizes; can be optionally fitted with a bottle sensor.

It is no problem to retrofit the device into an existing pipeline. The pipeline must be ripped up at an adequate point and fitted with two counter flanges. Then the **Sampler PS4-S** which is fitted with a tube piece and the required bottles is just mounted.

The triggering is carried out automatically by using the **DIESSEL** data capture device **ZEVODAT-M**.

**DIESSEL** GmbH & Co.  
P.O. Box 10 03 63  
D-31103 Hildesheim  
Germany  
☎ (0)5121-742-0

**Peristaltic Sampler**  
**PS4-S**  
**with separate Electronics**

**D 75.25 E**

Issued: 06.2000

Page -1- of -2- pages

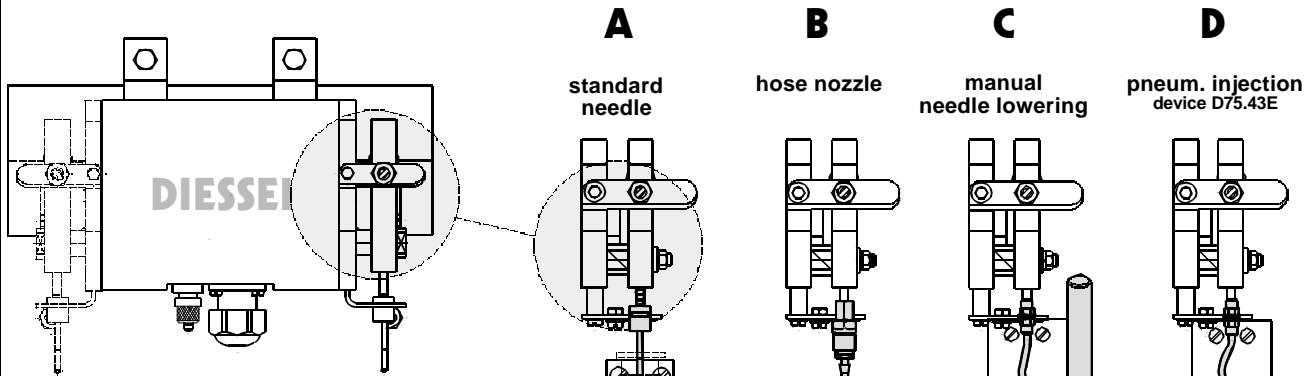

### Version "A" with Filling Needle

The sample volume is directly filled to a sample bottle which is not closed.

### Design "B" with Hose Nozzle

It is possible to carry out a low-germ filling of the taken sample by using a hose which is fixed to the hose nozzle at the sampler and by applying the adequate options.

### Options: Version "C" or "D"

- Injection needle for a low-germ sampling process
- Sample bottle with slitted stopple made of caoutchouc.
- Magazine for several sample bottles for a fully automatic sampling process.

\*) with connection for rinsing

## Technical Data

<b>Pipe connection</b>	Connection of different nominal widths possible. Flange connection PN10 (small flange)			
<b>Sampling volume</b>	10 ml/min min. 140 ml/min max. at pü = 0 bar in the pipeline			
<b>Pressure in the product pipe</b>	0.5 - 2.5 bar (absolute). Special design to be used on the suction side of a pump! (Special adapter!)			
<b>Materials</b>	Stainless steel no. 1.4301 / Housing: Al laquered Silicone hose			
<b>Operating voltage</b>	10 ... 30 V DC			
<b>Current consumption for 2 motors (max.)</b> when using one motor when using two motors	<b>Quiescent current</b>	12 V DC 0.3 A	24 V DC 0.15 A	30 V DC 0.12 A
	<b>Operating current</b>	2.7 A	1.3 A	1.0 A
	<b>Operating current</b>	5.2 A	2.3 A	1.8 A
<b>Fuse protection of the device</b>	7.5 A (brown)			

## Connection Scheme

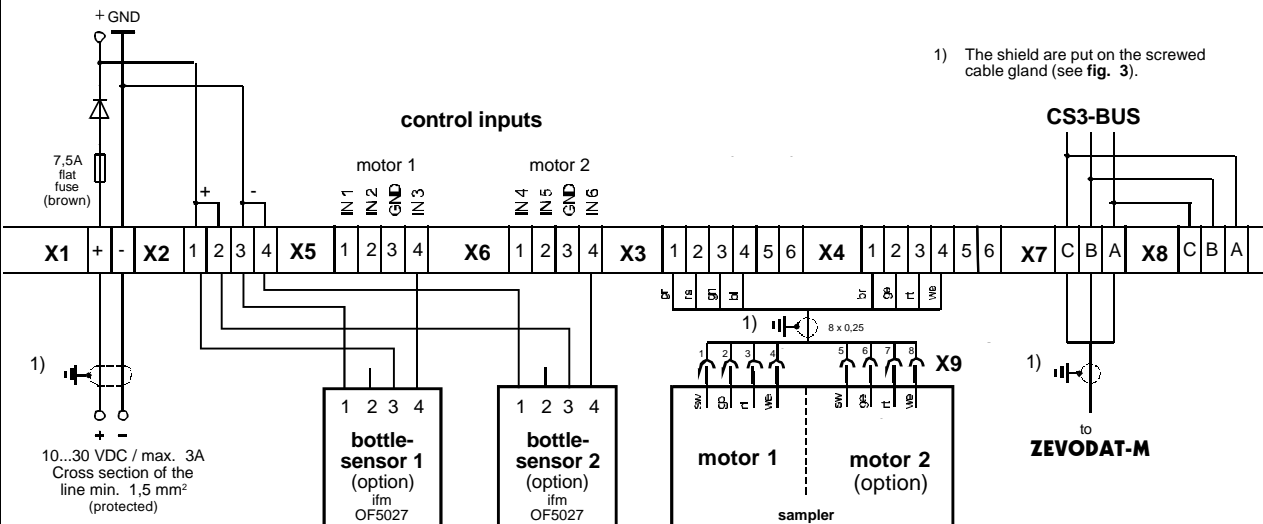

D75.25E