

Description

By means of the electromagnetic flow meter type **IZM** both the flow and the volume of liquids can be measured with high accuracy.

The measurement is independent of the product's pressure, temperature, viscosity, and density. Due to the smooth measuring tube the measuring method is wear-resistant, extremely rugged and, consequently, nearly unaffected by interferences. The transmitter has nearly no pressure drop.

The calibration data of the transmitter are stored in a **MEMbox**. The device is immediately ready for measurement after inserting the **MEMbox** into the converter.

Special mathematical procedures, combined with some newly developed circuit methods, permit a reliable, precise flow measurement, which is nearly resistant against process-dependent or environmental variables. The flow and volume data are available for further processing either digitally or via a serial computer interface (BUS-oriented). Of course, the incorporation of a display including keyboard is possible whenever desired.

For volume measurements which are subject to official trade use, we have available devices suitable for calibration. Provided with appropriate control and monitoring equipment, the devices obtained the qualification approval by the German national legal metrology service PTB. If a display is incorporated it can be used for W&M approved applications.

separated design

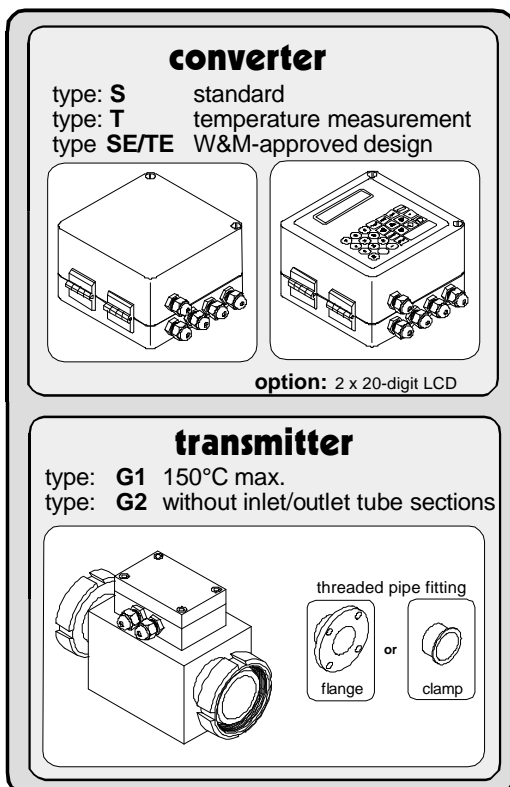

integrated design

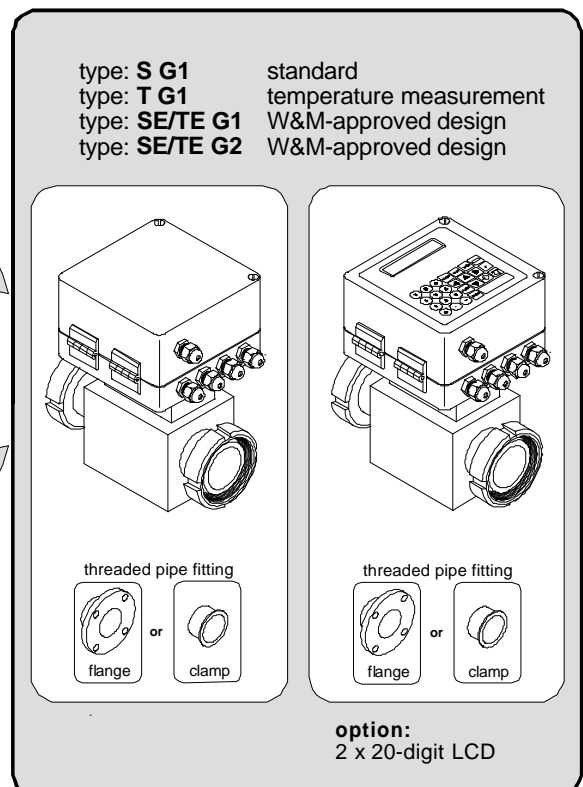

Options:

- Keyboard and 2 x 20-digit LC display
- Quantity preselection control (converter type **TV / TEV**, see data sheet D43.54)
- 2-component in-line blenders (converter type **R**, see data sheet D 46.64)
- Sampler control (converter type **P**, see data sheet D 55.07)

DIESSEL GmbH & Co.
P.O Box 10 03 63
D-31103 Hildesheim
Germany
☎ (0)5121-742-0

Electromagnetic Flow Meter
IZM

D 12.70 E

Issued: 07.2000

Page -1- of - 4 - pages

Special Features

- high precision/reproducibility
- typical tolerance of measured values: 0.25 % of measured value in nominal range 1 : 10 or 1 : 20
- nearly no pressure drop
- different designs available
- large temperature range
- measurement independent of density, viscosity, pressure and temperature
- wear-resistant measuring principle
- transmitter suitable for CIP
- easily installed and commissioned
- transmitter housing made of stainless steel
- self-monitoring with automatic error diagnosis
- remote maintenance via CS3-BUS connection (BUS-oriented interface) possible

- electronic system or transmitter can be exchanged without alignment due to **MEMbox** memory
- automatic conversion of measuring range in case of exceeding the flow rate
- measurement in forward and reverse flow
- user-friendly parameterization
- output of measured values unaffected by interferences (voltage-free outputs)
- multi-channel and safe pulse transmission for counting suitable for W&M applications
- date and time (type **T/TE**)
- electromagnetically compatible design 
- suitable for use on vehicles acc. to DIN40839 and OIML Doc. 11/A1.4.X. standards
- design suitable for W&M approved applications
- temperature measurement with external Pt100 (type **T/TE**)

Technical Data

Transmitter		G1	G2
Connections and nominal size:	FG flange	DN 25, 40, 50, 80, 100, 125, 150	DN 50, 65, 80
	Tube fitting DIN 11 851	DN 10, 15, 25, 32, 50, 65, 80	DN 50, 65, 80
	Clamp	½" (connections 1"), 1½", 2", 3" (connections 4")	2", 3" (connections 4")
Materials:	Measuring pipe:	Material-no.: 1.4301	
	Liner:	PTFE	FEP
	Electrodes:	Material-no.: 1.4404	
	Transmitter housing:	Material-no.: 1.4301 (blasted)	
	Connection housing:	Cast aluminium (with special corrosion-proof varnish)	
Electrical connection:	Coil supply to transmitter: 2 x 0,75 mm ² , shielded Electrode signal from transmitter: 3 x 1,5 mm ² CY, shielded Typical standard cable length: 5 m each (separated design) Coil resistance: 100 Ohms Calibration data in MEMbox to be plugged into converter		
Product temperature:	150°C max. / integrated design 120°C	50°C max.	
Cleaning temperature	150°C max. / integrated design 130°C	80°C max. for 30 min.	
Product conductivity:	5µS/cm min.		
Admissible pressure:	0.5 bar min. abs. at 20°C, 10 bar max. (higher pressures on demand)		
Flow velocities:	0,03 - 10 m/s		

Converter type S or SE

Power supply:	a) 115 / 230 V AC (-15% / +10%) 0,15A/0,07A b) 10 ... 30 V DC / 0,8 ... 0,3A	Housing:	Cast aluminium Protective type: IP 65
Power consumption:	max. 15 VA / 8 Watt	Serial interface:	RS485 57600 baud DIESSEL CS3 BUS protocol
Fuse protection:	AC supply T315 mA DC supply M2,5 A	Indication of measured values (option):	2 x 20-digit - alphanumeric, illuminated LC display (digit height 5 mm) with keyboard
Digital outputs:	4 x Optocoupler; load 30V max. / 20 mA max. (passive) volume pulses, status pulses	Digital inputs:	4 x Optocoupler; activation: 10 ... 30V DC - count interruption (standby) and zeroing
Analog output:	0/4 ... 20 mA (active), load 500 Ω max.	Ambient temperature:	- 25 ... + 55 °C

Converter type T or TIE

Special features:	1.) Temperature measurement via external Pt100-Sensor 2.) Printer connection (RS232) for protocol or ticket print out with date/time information		
Power supply:	a) 115 / 230 V AC (-15% / +10%) 0.15A/0.07A b) 10 ... 30 V DC / 0.8 ... 0.3A	Housing:	Cast aluminium Protective type: IP 65
Power consumption:	15 VA max. / 8 watts	Serial interface:	RS485 57600 baud (DIESSEL - BUS) or RS 232 (300 ... 19.200 baud)
Fuse protection:	AC supply T315 mA DC supply M2.5 A	Indication of measured values (option):	2 x 20- digit - alphanumeric, illuminated LC display (digit height 5 mm) with keyboard
Digital outputs:	4 x Transistor load 30 V max./250 mA max. passive) Volume pulses, status pulses	Digital inputs:	2x Optocoupler; activation: 10...30V DC - count interruption (standby) and zeroing
Temperature input	4-wire Pt100	Ambient temperature:	- 25 ... + 55 °C

Measuring Ranges and Tolerances:

Nominal width mm	Minimum measuring range* l/h	Maximum measuring range l/h	Flow rate at a flow velocity of 1 m/s	Measuring tolerance		Unit
				< 0,25 %	< 1 %	
DN 10	17 - 170	450 - 4.500	280	> 60	> 17	l/h
DN 15	25 - 250	600 - 6.000	640	> 90	> 30	l/h
DN 25	60 - 600	2.000 - 20.000	1.800	> 240	> 60	l/h
DN 32	100 - 1.000	3.000 - 30.000	2.900	> 400	> 100	l/h
DN 40	100 - 1.000	4.500 - 45.000	4.500	> 400	> 100	l/h
DN 50	200 - 2.000	6.500 - 65.000	7.000	> 800	> 200	l/h
DN 65	400 - 4.000	10.000 - 100.000	12.000	> 1.400	> 400	l/h
DN 80	600 - 6.000	20.000 - 200.000	18.000	> 2.400	> 600	l/h
DN 100	1.500 - 15.000	40.000 - 400.000	28.000	> 6.000	> 1.500	l/h
DN 125	2.500 - 25.000	72.000 - 720.000	44.000	> 10.000	> 2.500	l/h
DN 150	4.000 - 40.000	120.000 - 1.200.000	64.000	> 16.000	> 4.000	l/h

* the minimum flow rate for measurements appropriate for W&M applications is approx. 4 times higher

General Data

Measurable are all liquid products with a minimum conductivity of 5 µS/cm. Due to the measuring principle both laminar and turbulent flows can be measured.

A major precondition for correct measurements is a continuously filled measuring pipe. Any control devices or other incorporations are to be installed behind the electromagnetic flow meter. An installation into an ascending tube is recommended. In case of horizontal installation, the electrode axis must be in horizontal direction, too.

Inlet and Outlet Lines:

The length of the inlet and outlet lines depends on the conditions in front of and behind the transmitter. Minimum requirements should be:

Transmitter	not W & M approved		W & M approved	
	inlet	outlet	inlet *	outlet *
G1	5 x DN	3 x DN	10 x DN	5 x DN
G2	0	0	2 x DN	0

* In case of asymmetric flow profiles, e.g. due to valves or screens in front of the flow meter longer flow inlets and outlets become necessary. Regarding W&M approved systems the conditions of the approval authorities have to be met.

Dimensions

A) Transmitter

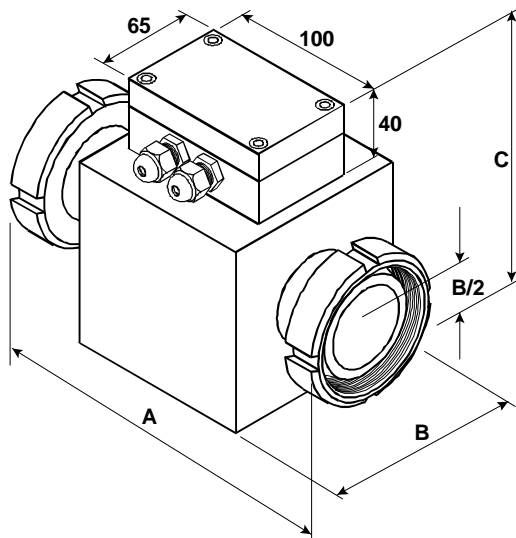

Type	DN	A [mm]	B [mm]	C [mm]	Weight [kg]
G 1	10	200	75	115	5
	15	200	75	115	5
	25	200*	100	140	6
	32	200*	100	140	7
	40	200*	130	170	8
	50	200*	130	170	8
	65	200**	165	205	12
	80	200**	165	205	14
	100	250	190	230	18
	125	250	215	255	22
150	250	240	280	24	
G 2	50	200	100	140	8
	65	250	120	160	12
	80	250	150	190	14

* Design with DIN-flanges: 225 mm
 ** Design with DIN-flanges: 225 mm

B) Converter

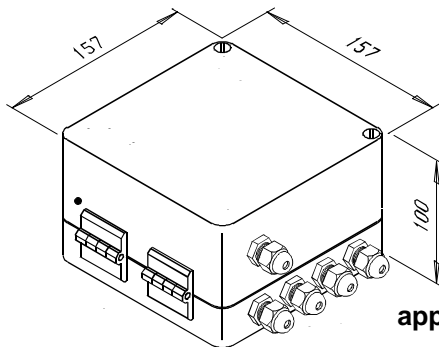

approx. 3 kg

ATTENTION

To be observed for mounting purposes:
 in case of open in direction to the flap
 side + 80 mm

C) Integrated design

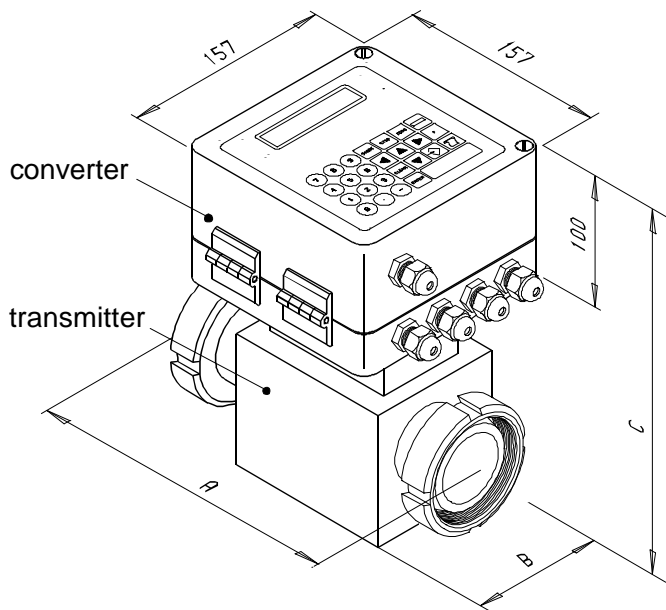

Transmitter Type	DN	A [mm]	B [mm]	C [mm]	Weight [kg]
G 1	10	200	75	205	8
	15	200	75	205	8
	25	200*	100	230	9
	32	200*	100	230	10
	40	200*	130	260	11
	50	200*	130	260	11
	65	200**	165	295	15
	80	200**	165	295	17
	100	250	190	320	21
	125	250	215	345	25
150	250	240	370	27	
G 2	50	200	100	230	11
	65	250	120	250	15
	80	250	150	280	17

ATTENTION:

to be observed for mounting purposes: in case of open cover: value **C + 120 mm** and in direction to the flap side + 80 mm.