

## Sanitary Bag Filter – SANICIP™

Niro has developed the next generation of bag filters, the SANICIP™, for installation in spray drying systems. This will replace exhaust separators such as cyclones, wet scrubbers, and conventional bag filters.

### Advantages

The advantages of selecting a spray dryer with the SANICIP™ bag filter comprise:

#### *Investment*

- Smaller building
- Reduced process equipment

#### *Operation*

- Simpler plant
- Higher plant capacity
- Less product degradation
- Reduced dust emission to atmosphere
- Reduced energy consumption
- Reduced water consumption

#### *Hygiene*

- Sanitary design according to USDA or equal standards

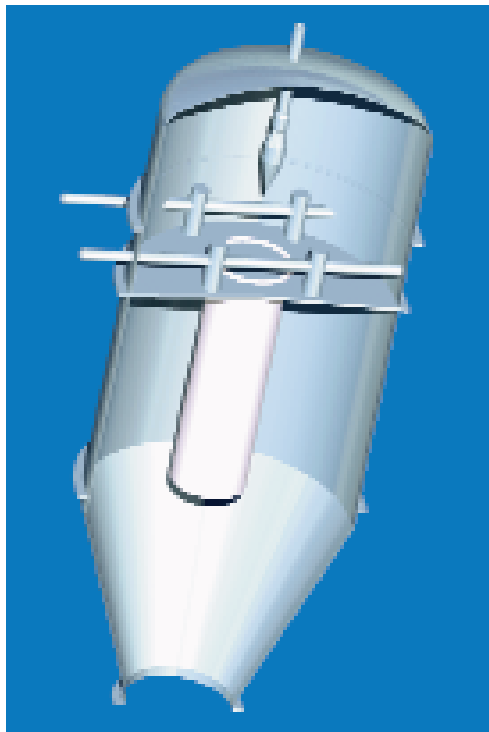

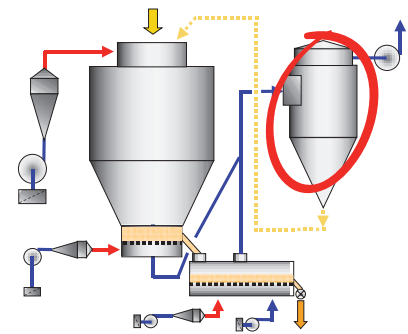
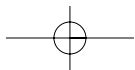

## Niro Sanitary Bag Filter – SANICIP™

Based on almost ten years of research, development and testing, the SANICIP™ bag filter is becoming standard on almost all types of dryers supplied by Niro for operation in the dairy, food, and chemical industries.

### Design Features

The exhaust air system has been improved and now features

- a simpler design of the clean air plenum
- larger filter bags
- a newly developed purge air system (patent pending)

The new purge air system allows individual purging of each bag thereby avoiding a pressure surge back into the chamber. It can operate with a high air-to-cloth ratio. The fluidized bottom ensures a constant powder flow out of the filter. The low pressure drop across the filter gives more economic drying. Optimum usage of compressed air and secondary air eliminates the need for Venturi-throats in the bags.

The cleaning-in-place (CIP) system has been designed for cleaning of the entire bag filter, i.e.

- clean-air plenum
- filter bags, which are cleaned from the inside
- tube sheet
- shell

with minimum consumption of water, acid, and caustic.

- ① Clean-air plenum with reverse jet nozzles.
- ② Bag filter section with exhaust air inlet and internal/external CIP nozzles.
- ③ Conical section with bottom fluidization.

Reverse jet nozzles

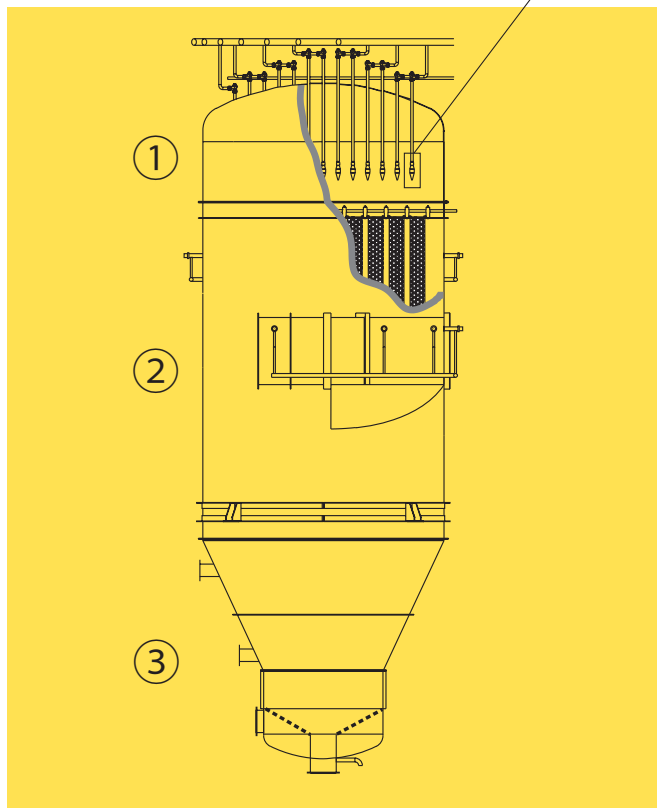

GEA Process Engineering Inc. • 9165 Rumsey Road • Columbia, MD 21045  
 Tel: 410-997-8700 • Fax: 410-997-5021 • Email: gea.pe.na@geagroup.com  
 GEA Process Engineering Inc. • 1600 O'Keefe Road • Hudson, WI 54016  
 Tel: 715-386-9371 • Fax: 715-386-9376 • Email: gea.pe.na@geagroup.com  
 Web: www.niroinc.com

