



Hygienic design for **Water filling**

Mineral water filling specifically demands hygiene and safety and GEA Procomac answer is a solution without compromise that meets clean environment requirements: the volumetric electronic Fillstar FX. Being the evolution of aseptic filling valve, Fillstar FX fitted with electronic control type filling valves is featured by the absence of contact between filling nozzle and bottle mouth.

It is easy to clean both internally and externally. It meets the request of automatic cleaning having permanently installed type dummy bottles, complete with automatic insertion/removal mechanism controlled from operator panel. When in waiting position the dummy bottles are kept sealed, for better machine hygiene. Furthermore the machine has short cleaning

time and cleaning cycle flexibility.

The volumetric electronic design guarantees, through magnetic flow meters, the high performance of the machine, proved by the high level of filling accuracy.

Bottles are handled through the machine (as well as filled) in suspended position, by neck grippers: less change parts, reduced container change over time thanks to the pitching star-wheel which delivers the containers at the right pitch instead of an infeed scroll. To improve hygienic environment the machine can be equipped with top covering hood (machine upper side), and laminar air flow system (HEPA EU14) equipped with pre-filter upstream the blower and absolute filter downstream the blower.

Volumetric electronic filler **Fillstar FX**

Features

- Magnetic flow meters.
- Excellent features for filling of still liquids.
- No contact between filling nozzle and the bottle neck.
- Automatic dummy bottle insertion and extraction for closed-loop CIP (international patent).
- User-friendly touchscreen control panel.

Advantages

- Advanced product/container flexibility:
 - complete neck handling system: fast bottle changeover;
 - self-adapting grippers to handle bottles with different neck diameters available as an option.
- No contact between bottle and filling head (optimal hygiene).
- Fully automatic CIP and SIP cycles.

As a plus confirming hygiene filling conditions, GEA Procomac is one of the first companies having achieved the 3A international certification for its FX filling valve based on the new "third party verification" procedure.

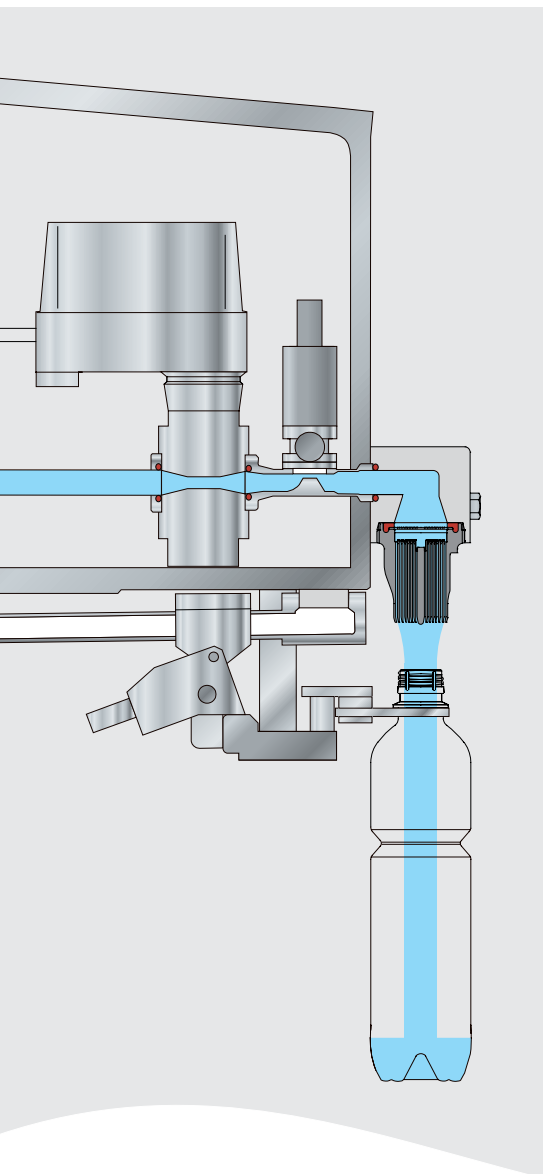

GEA Procomac filling bloc for water in Aero version, with glass guards and absence of basement: best accessibility and cleanability. Laminar air flow system and top covering hood are included to improve hygienic environment.



Other possibilities for water filling

Thanks to their long experience in manufacturing complete filling lines, GEA Procomac can offer several fillers according to the different needs of beverage and specifically for still and carbonated water. GEA Procomac range lists: gravity, mechanical or pneumatic, counterpressure and volumetric electronic fillers.

Fillstar SF gravity level filler is featured by a mechanical filling valve with one silicon membrane which acts as product interception seal and connection seal between fixed and

moving part of the filling head.

Fillstar PET2 mechanical counterpressure filler is a sturdy machine which requires very low maintenance.

Fillstar PET2 ADV 3.3 pneumatic counterpressure filler main features are: fast changeover, pipelined snift, separate return for bottle air (this means hygiene when filling still water).

All fillers can be manufactured in Synchro version (blower-filler bloc) for reduced footprint and customer preference.



GEA Procomac
GEA Process Engineering Inc.
1600 O'Keefe Road
Hudson, WI 54016
USA
Tel.: 715 386 9371
Fax: 715 386 9376
E-mail: info@niroinc.com
Website: www.niroinc.com / www.procomac.it